

## Cisco Aironet 1200 Series Access Point



### Product Overview

The Cisco Aironet® 1200 Series Access Point sets the enterprise standard for next-generation high performance, secure, manageable, and reliable wireless local-area networks (WLANs), while also providing investment protection because of its upgrade capability and compatibility with current standards. The modular design of the Cisco Aironet 1200 supports Institute of Electrical and Electronic Engineers (IEEE) 802.11a and 802.11b technologies in both single- and dual-mode operation. You can configure the Cisco Aironet 1200 to meet customer-specific requirements at the time of purchase and then reconfigure and upgrade the product in the field as these requirements evolve. In addition, the Cisco Aironet 1200 Series creates a wireless infrastructure that provides customers with maximum mobility and flexibility, enabling constant connection to all network resources from virtually anywhere wireless access is deployed (Figure 1).



### Modular Design for Customer-Specific Functionality and Upgrade Capability for Investment Protection

The Cisco Aironet 1200 Series protects current and future network infrastructure investments. Compliant with IEEE 802.11a and 802.11b standards, the modular design of the Cisco Aironet 1200 Series allows for both single- and dual-band configuration plus field upgradability to modify these configurations as your requirements and technology evolve. The 802.11a radio supports data rates of up to 54 Mbps and eight non-overlapping channels that offer high performance as well as maximum capacity and scalability. The 802.11b radio provides data rates up to 11 Mbps and three non-overlapping channels to support widely deployed 802.11b clients. The Mini-PCI form factor of the 802.11b radio allows for upgrade to higher-speed 2.4 GHz technologies such as the draft IEEE 802.11g standard.

Figure 1 Configure the Cisco Aironet 1200 to support 802.11b, 802.11a, or both technologies in a single device. Legacy, current, and future clients can roam between access points while maintaining reliable and uninterrupted access to all network resources.

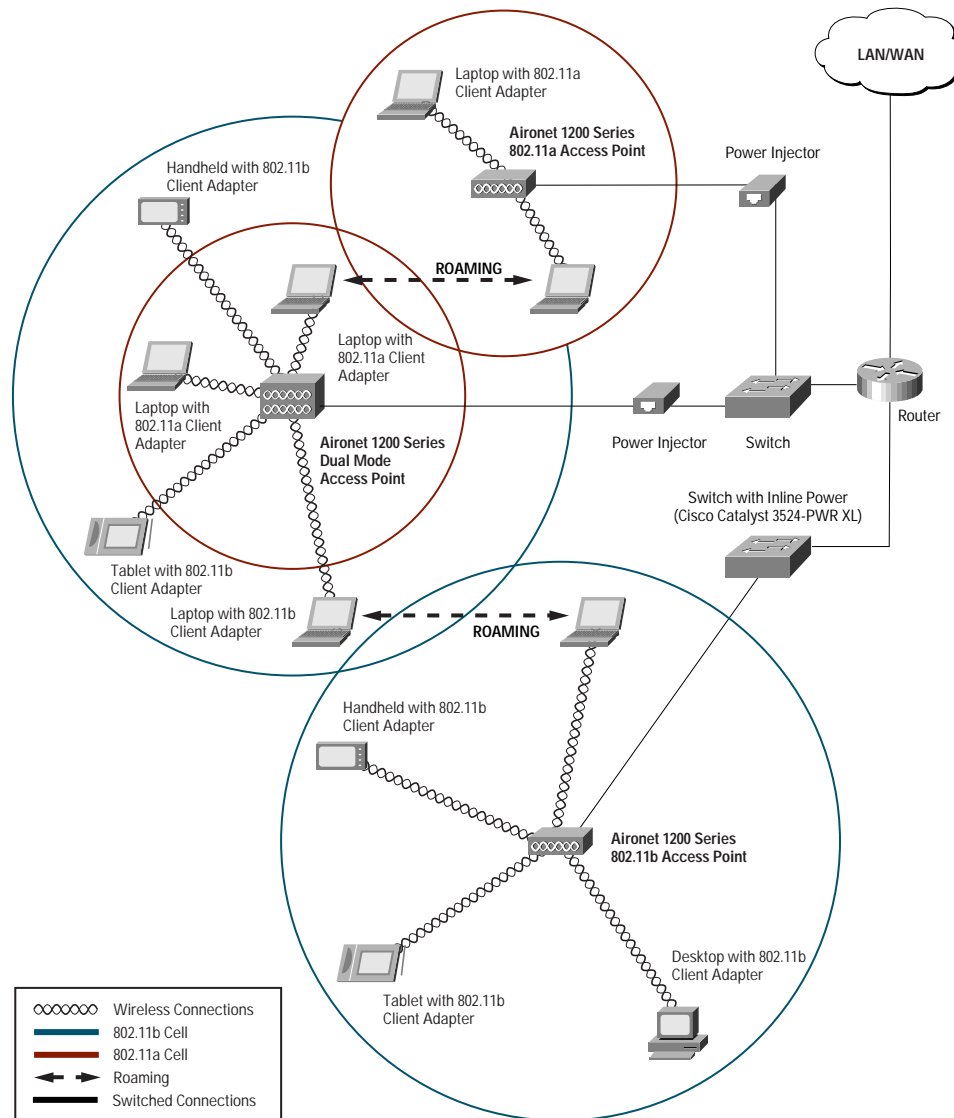



## Enterprise-Class Security Solution

Wireless LAN security is a primary concern. The Cisco Aironet 1200 Series secures the enterprise network with a scalable and manageable system featuring the award-winning Cisco Wireless Security Suite. Based on the 802.1X standard for port-based network access, the Cisco Wireless Security Suite takes advantage of the Extensible Authentication Protocol (EAP) framework for user-based authentication. (Figure 2).

The Cisco Wireless Security Suite interoperates with a range of client devices. It supports all 802.1X authentication types, including EAP Cisco Wireless (LEAP), Extensible Authentication Protocol-Transport Layer Security (EAP-TLS) and types that operate over EAP-TLS, such as Protected Extensible Authentication Protocol (PEAP), EAP-Tunneled TLS (EAP-TTLS) and EAP-Subscriber Identity Module (EAP-SIM). A wide selection of Remote Access Dial-In User Service (RADIUS) servers, such as the Cisco Secure Access Control Server (ACS), can be used for enterprise-class centralized user management that includes:

- Strong, mutual authentication to ensure that only legitimate clients associate with legitimate and authorized network RADIUS servers
- Dynamic per-user, per-session encryption keys that automatically change on a configurable basis to protect the privacy of transmitted data
- Stronger WEP keys provided by pre-standard Temporal Key Integrity Protocol (TKIP) enhancements such as message integrity check (MIC), per-packet keys via initialization vector hashing, and broadcast key rotation
- RADIUS accounting records for all authentication attempts

Figure 2 The Cisco Wireless Security Suite is an Enterprise-Class Security System Based on the 802.1X Architecture

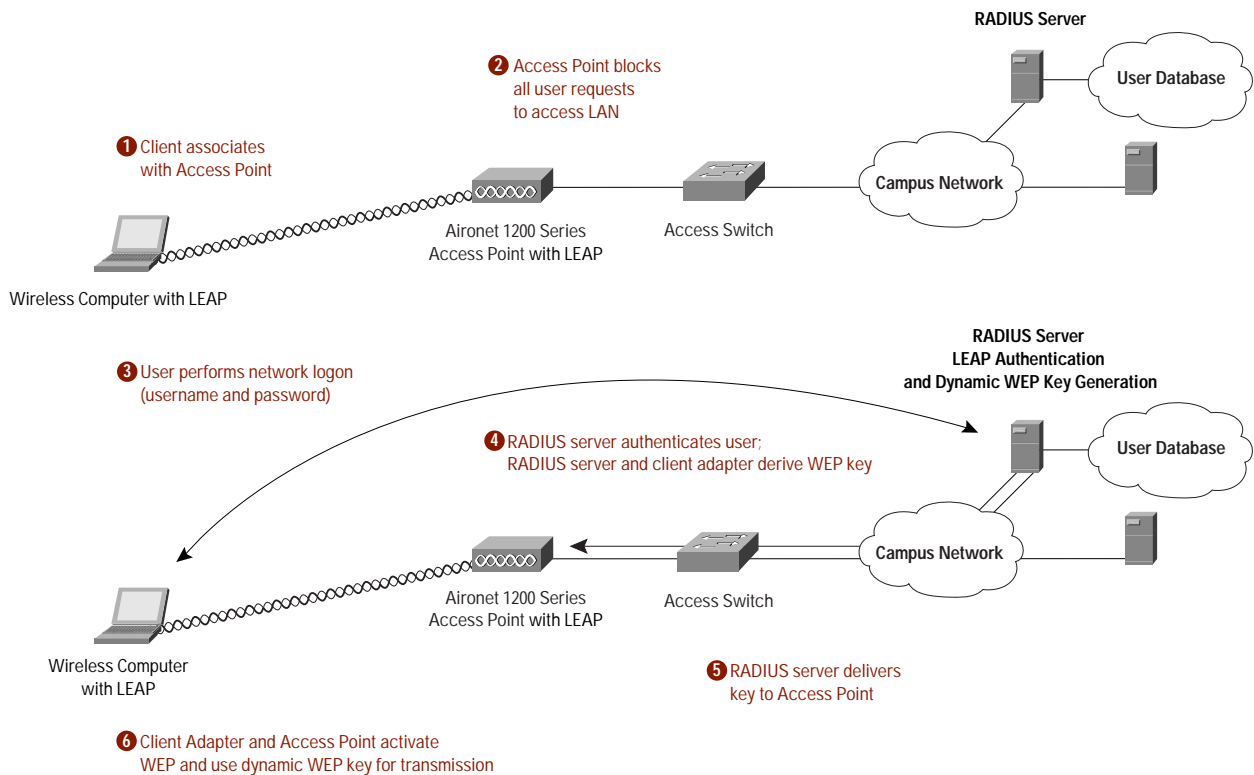



### Investment Protection for Future-Proof Networks

With large storage capacity and support for Cisco management tools, the Cisco Aironet 1200 Series provides the capacity and the means to upgrade firmware and deliver new features as they become available. It features more than four times the amount of storage required by the initial firmware load and the tools for IS professionals to centrally and automatically upgrade firmware on often remote access points across the enterprise. For additional investment protection, the Cisco Aironet 1200 Series comes complete with an integrated mounting system that secures the device using the customer's choice of laptop security cables or standard padlocks (Figure 3). The reliability of the 2.4 GHz solution also makes the Cisco Aironet 1200 Series a wise investment. It provides field-proven reliability, featuring a Cisco Aironet fourth-generation 802.11b radio. The 5 GHz radio maximizes capacity and performance, delivering up to 54 Mbps data rates on all eight available channels and allowing the wireless network to scale to accommodate a large number of users. With the Cisco Aironet 1200 Series, a single access point can add capacity to support new users by simultaneously operating one radio for high-speed 802.11a networked clients while maintaining another radio for 802.11b clients. The redundant hot-standby feature also aids in the overall reliability of the network by providing a backup access point in the rare case of a failure.

Figure 3 Cisco Aironet 1200 Series Mounting Bracket



### Installation Options Increase Flexibility

As the popularity of wireless LANs increases, enterprises are installing access points in a growing variety of facilities, locations, and orientations. The Cisco Aironet 1200 Series is designed with this in mind. The cast aluminum-cased device with its broad operating temperature range provides the ruggedness required in factories and warehouse installations while still meeting the aesthetic requirements of the enterprise. Support for both inline power over Ethernet, as well as local power, maximizes powering options. The access point and integrated mounting system are designed for installation on walls, below ceilings, and, with its plenum ratable metal case, above suspended ceilings. Both 802.11a and 802.11b radios provide a variety of transmit power settings to adjust coverage area size. This, coupled with the broadest selection of 2.4 GHz and integrated 5 GHz antennas in the industry, provides users with unparalleled flexibility in cell size and coverage patterns.



### Unique 802.11a 5 GHz Antenna Design for Optimal Coverage

To extend the flexibility of deployments, the 802.11a radio module incorporates an articulating antenna paddle that contains both omni directional and patch antennas (Figure 4). For ceiling, desktop, or other horizontal installations, the omni directional antenna provides optimal coverage pattern and maximum range. For wall mount installations, the patch antenna provides a hemispherical coverage pattern that uniformly directs the radio energy from the wall and across the room (Figure 5). Both the omni directional and patch antennas provide diversity for maximum reliability even in high multipath environments such as offices and other indoor environments. Cisco provides this level of 5 GHz antenna flexibility and reliability to suit all installation scenarios.

Figure 4 The design of the 802.11a radio module features an integrated omni directional and patch antenna.



Figure 5 Cisco's innovative antenna module provides two distinct coverage patterns to address different access point installation orientations.

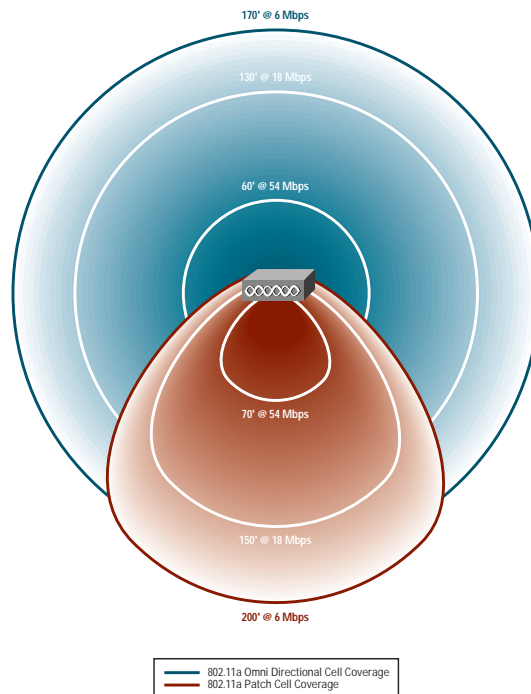



## Integrated Management Tools for Rapid Configuration

The Cisco Aironet 1200 Series simplifies wireless LAN management because many of the same management tools and capabilities available in wired networks are used on the wireless network (Figure 6). The 1200 Series supports network management through Simple Network Management Protocol (SNMP), Telnet, and a Web browser to aid in troubleshooting, monitoring, software download, and event logging. The CiscoWorks™ Wireless LAN Solution Engine is also available as a management tool. Table 1 provides product features and benefits, Table 2 provides product specifications, and Table 3 provides product system requirements for the Cisco Aironet 1200 Series.

Figure 6 The access point management system Express Setup screen provides all the settings required for basic configuration of the access point.

Table 1 Product Features and Benefits

Feature	Benefit
<b>Modular platform for single or dual band operation</b>	The access point can be configured for either 802.11b only, 802.11a only, or for simultaneous support of 802.11b and 802.11a to provide the maximum number of channels and maximum available data rates in a single device.
<b>Field upgradable radios</b>	Flexibility and investment protection is provided through field-upgradable card bus and mini-PCI radios. CardBus-based 802.11a modules can easily be fitted into installed Cisco Aironet 1200 Series access points.
<b>5 GHz integrated antennas</b>	Unique articulating antenna paddle incorporates high-gain omni directional and hemispherical patch antennas to deliver two distinct coverage patterns.
<b>2.4- and 5 GHz Diversity Antennas</b>	Diversity antennas for both the 2.4- and 5 GHz radios ensures optimum performance in high-multipath environments such as offices, warehouses, and other indoor installations.



Table 1 Product Features and Benefits (Continued)

Feature	Benefit
<b>Two reverse-polarity threaded naval connectors (RP-TNC) for external 2.4 GHz antenna connection</b>	Diversity support for the 2.4 GHz radio to improve reliability in high-multipath environments. The RP-TNC connectors are compatible with the Cisco Aironet optional antennas, enabling WLAN architects to customize radio coverage for specific deployment scenarios.
<b>Eight Mbytes Flash memory</b>	Provides memory space for future firmware upgrades and supports new 802.11 standards and advanced features.
<b>Support for Cisco Discovery Protocol and Software Image Manager (SWIM) within CiscoWorks Resource Essentials (RME)</b>	Allows centralized and automatic firmware upgrades on remote access points across the enterprise.
<b>Standard 802.11b radio with 100-mW maximum transmit power and 85-dBm receive sensitivity at 11 Mbps data rate</b>	2.4 GHz radio offers superior radio performance that results in industry-leading range. The greater the range of the access point, the fewer access points needed, resulting in lower total system cost.
<b>802.11a radio module provides 40-mW maximum transmit power for UNII 1 and UNII2 bands and -68 dBm (typical) receive sensitivity at 54 Mbps data rate</b>	Superior 5 GHz radio design provides industry-leading performance and receive sensitivity and maximum capacity through eight non-overlapping channels in the UNII1 and UNII 2 bands.
<b>Support for both line power over Ethernet and local power (see Figures 7, 8, and 9)</b>	To decrease the cost and complexity of installation, the Cisco Aironet 1200 Series can be powered over an Ethernet cable, eliminating the need to run expensive AC power to remote access-point installation locations. Depending upon radio configuration, the Cisco 1200 Series can be powered via Cisco line-power-enabled switches, multiport midspan power panels, or single-port power injectors. In instances where AC power is available at the installation location, the power supply for the Cisco Aironet 1200 Series can be plugged into an electrical outlet.
<b>Aesthetically pleasing cast aluminum case, Underwriters Laboratories (UL) 2043 certification, and extended operating temperature (-20 to 55°C or -4 to 131°F)</b>	The product design meets the aesthetic requirements of the enterprise and the rugged features support deployment in factories, warehouses, and the outdoors (in a NEMA enclosure). The broad operating temperature range and UL 2043 certification for plenum rating requirements set by local fire codes supports installation in environmental air spaces such as areas above suspended ceilings.
<b>Multipurpose mounting bracket</b>	Flexibility of the multipurpose mounting bracket gives numerous deployment options for site-specific requirements.
<b>Two separate locking mechanisms for the access point and radio</b>	Theft deterrence has become a requirement as wireless LANs proliferate into public areas. Additional investment protection is provided with built-in locking mechanisms.



Figure 7 With the 802.11a, or with both the 802.11a and 802.11b radios installed, the Cisco Aironet 1200 Series can be powered over Ethernet with the optional inline power injector.

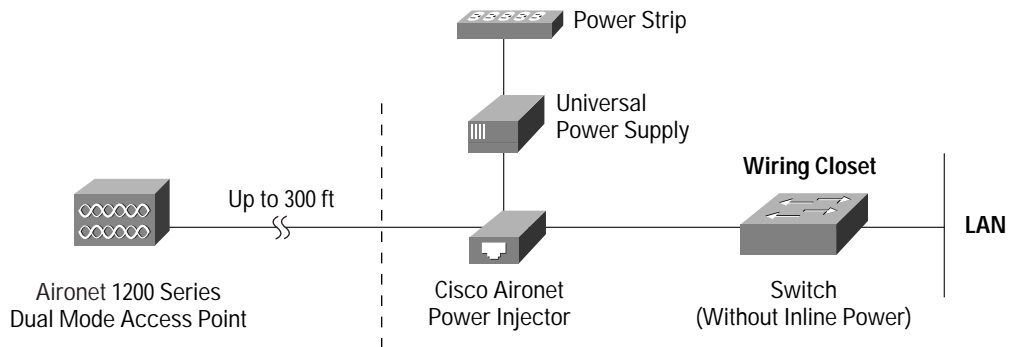

Figure 8 With only the 802.11b radio installed, the Cisco Aironet 1200 can use a Cisco Catalyst 3524-PWR XL for its power over Ethernet.

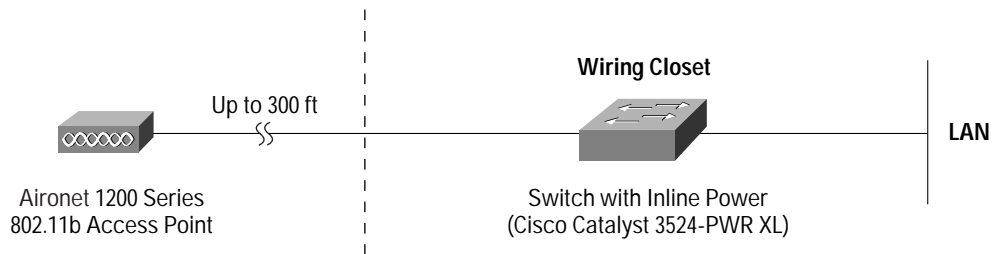

Figure 9 With only the 802.11b radio installed, a Cisco Catalyst Inline Power Patch Panel can be used to power the access point over Ethernet.

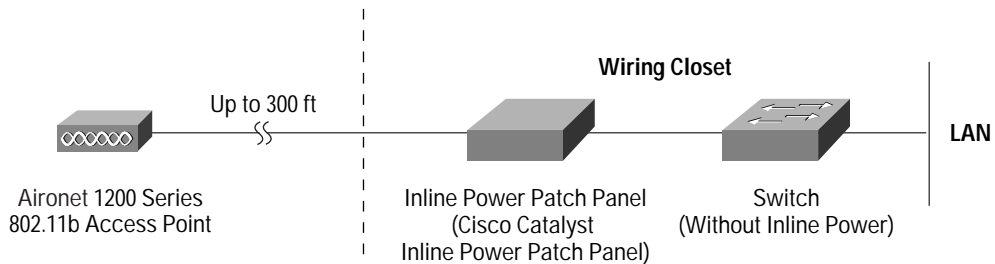



Table 2 Product Specifications

	With 802.11a radio installed	With 802.11b radio installed	With both 802.11a and 802.11b radio installed
<b>Part number</b>	Configurable: AIR-AP1200 and AIR-RM20A-x-K9 (x=Regulatory Domain) Pre-Configured: <ul style="list-style-type: none"> <li>• AIR-AP1220A-x-K9</li> <li>• A=FCC</li> <li>• S=Singapore</li> <li>• T=Taiwan</li> <li>• J=TELEC (Japan)</li> </ul> Not all regulatory domains have been approved. As they are approved, the part numbers will be available on the Global Price List.	Configurable: AIR-AP1200 and AIR-MP20B-x-K9 (x=Regulatory Domain) Pre-configured: <ul style="list-style-type: none"> <li>• AIR-AP1220B-x-K9</li> <li>• A=FCC</li> <li>• C=MII (China)</li> <li>• E=ETSI</li> <li>• I=Israel</li> <li>• J= TELEC (Japan)</li> </ul> Not all regulatory domains have been approved. As they are approved, the part numbers will be available on the Global Price List.	Configurable: AIR-AP1200, AIR-RM20A-x-K9 and AIR-MP20B-x-K9 (x=Regulatory Domain) Pre-configured: <ul style="list-style-type: none"> <li>• AIR-AP1220B-x-K9 and AIR-RM20A-x-K9</li> <li>• A=FCC</li> <li>• C=MII (China)</li> <li>• E=ETSI</li> <li>• I=Israel</li> <li>• J= TELEC (Japan)</li> <li>• S=Singapore</li> <li>• T=Taiwan</li> </ul> Not all regulatory domains have been approved. As they are approved, the part numbers will be available on the Global Price List.
<b>Radio module form factor</b>	<ul style="list-style-type: none"> <li>• CardBus (32-bit)</li> </ul>	<ul style="list-style-type: none"> <li>• Mini-PCI (32-bit)</li> </ul>	<ul style="list-style-type: none"> <li>• 802.11a: CardBus (32-bit)</li> <li>• 802.11b: Mini-PCI (32-bit)</li> </ul>
<b>Data rates supported</b>	<ul style="list-style-type: none"> <li>• 6, 9, 12, 18, 24, 36, 48, 54 Mbps</li> </ul>	<ul style="list-style-type: none"> <li>• 1, 2, 5.5, and 11 Mbps</li> </ul>	<ul style="list-style-type: none"> <li>• 802.11a: 6, 9, 12, 18, 24, 36, 48, 54 Mbps</li> <li>• 802.11b: 1, 2, 5.5, and 11 Mbps</li> </ul>
<b>Network standard</b>	<ul style="list-style-type: none"> <li>• IEEE 802.11a</li> </ul>	<ul style="list-style-type: none"> <li>• IEEE 802.11b</li> </ul>	<ul style="list-style-type: none"> <li>• IEEE 802.11a</li> <li>• IEEE 802.11b</li> </ul>
<b>Uplink</b>	<ul style="list-style-type: none"> <li>• Autosensing 802.3 10/100BASE-T Ethernet</li> </ul>	<ul style="list-style-type: none"> <li>• Autosensing 802.3 10/100BASE-T Ethernet</li> </ul>	<ul style="list-style-type: none"> <li>• Autosensing 802.3 10/100BASE-T Ethernet</li> </ul>
<b>Frequency band</b>	<ul style="list-style-type: none"> <li>• 5.15 to 5.35 GHz (FCC UNII 1 and UNII 2)</li> <li>• 5.15 to 5.25 GHz (TELEC)</li> <li>• 5.15 to 5.25 GHz (Singapore)</li> <li>• 5.25 to 5.35 GHz (Taiwan)</li> </ul>	<ul style="list-style-type: none"> <li>• 2.412 to 2.462 GHz (FCC)</li> <li>• 2.412 to 2.472 GHz (ETSI)</li> <li>• 2.412 to 2.484 GHz (TELEC)</li> <li>• 2.412 to 2.462 GHz (MII)</li> <li>• 2.422 to 2.452 GHz (Israel)</li> </ul>	<ul style="list-style-type: none"> <li>• 5.15 to 5.35 GHz (FCC UNII 1 and UNII 2)</li> <li>• 5.15 to 5.25 GHz (TELEC)</li> <li>• 5.15 to 5.25 GHz (Singapore)</li> <li>• 5.25 to 5.35 GHz (Taiwan)</li> <li>• 2.412 to 2.462 GHz (FCC)</li> <li>• 2.412 to 2.472 GHz (ETSI)</li> <li>• 2.412 to 2.484 GHz (TELEC)</li> <li>• 2.412 to 2.462 GHz (MII)</li> <li>• 2.422 to 2.452 GHz (Israel)</li> </ul>
<b>Network architecture type</b>	<ul style="list-style-type: none"> <li>• Infrastructure, star topology</li> </ul>	<ul style="list-style-type: none"> <li>• Infrastructure, star topology</li> </ul>	<ul style="list-style-type: none"> <li>• Infrastructure, star topology</li> </ul>
<b>Wireless medium</b>	<ul style="list-style-type: none"> <li>• Orthogonal Frequency Division Multiplexing (OFDM)</li> </ul>	<ul style="list-style-type: none"> <li>• Direct sequence spread spectrum (DSSS)</li> </ul>	<ul style="list-style-type: none"> <li>• 802.11a: Orthogonal Frequency Division Multiplexing (OFDM)</li> <li>• 802.11b: Direct sequence spread spectrum (DSSS)</li> </ul>



Table 2 Product Specifications (Continued)

	With 802.11a radio installed	With 802.11b radio installed	With both 802.11a and 802.11b radio installed
<b>Media Access Protocol</b>	<ul style="list-style-type: none"> <li>Carrier sense multiple access with collision avoidance (CSMA/CA)</li> </ul>	<ul style="list-style-type: none"> <li>Carrier sense multiple access with collision avoidance (CSMA/CA)</li> </ul>	<ul style="list-style-type: none"> <li>Carrier sense multiple access with collision avoidance (CSMA/CA)</li> </ul>
<b>Modulation</b>	<ul style="list-style-type: none"> <li>(OFDM subcarrier)</li> <li>BPSK @ 6 and 9 Mbps</li> <li>QPSK @ 12 and 18 Mbps</li> <li>16-QAM @ 24 and 36 Mbps</li> <li>64-QAM @ 48 and 54 Mbps</li> </ul>	<ul style="list-style-type: none"> <li>DBPSK @ 1 Mbps</li> <li>DQPSK @ 2 Mbps</li> <li>CCK @ 5.5 and 11 Mbps</li> </ul>	OFDM: <ul style="list-style-type: none"> <li>BPSK @ 6 and 9 Mbps</li> <li>QPSK @ 12 and 18 Mbps</li> <li>16-QAM @ 24 and 36 Mbps</li> <li>64-QAM @ 48 and 54 Mbps</li> </ul> DSSS: <ul style="list-style-type: none"> <li>DBPSK @ 1 Mbps</li> <li>DQPSK @ 2 Mbps</li> <li>CCK @ 5.5 and 11 Mbps</li> </ul>
<b>Operating channels</b>	<ul style="list-style-type: none"> <li>FCC: 8</li> <li>TELEC (Japan): 4</li> <li>Singapore: 4</li> <li>Taiwan: 4</li> </ul>	<ul style="list-style-type: none"> <li>ETSI: 13; Israel: 7; North America: 11; TELEC (Japan): 14; MII: 11</li> </ul>	5 GHz Band: <ul style="list-style-type: none"> <li>FCC: 8</li> <li>TELEC (Japan): 4</li> <li>Singapore: 4</li> <li>Taiwan: 4</li> </ul> 2.4 GHz Band: <ul style="list-style-type: none"> <li>ETSI: 13; Israel: 7; North America: 11; TELEC (Japan): 14; MII: 11</li> </ul>
<b>Nonoverlapping channels</b>	<ul style="list-style-type: none"> <li>Eight (FCC only)</li> <li>Four (Japan, Singapore, Taiwan)</li> </ul>	<ul style="list-style-type: none"> <li>Three</li> </ul>	<ul style="list-style-type: none"> <li>Eleven</li> </ul>
<b>Receive sensitivity</b>	<ul style="list-style-type: none"> <li>6 Mbps: -85 dBm</li> <li>9 Mbps: -84 dBm</li> <li>12 Mbps: -82 dBm</li> <li>18 Mbps: -80 dBm</li> <li>24 Mbps: -77 dBm</li> <li>36 Mbps: -73 dBm</li> <li>48 Mbps: -69 dBm</li> <li>54 Mbps: -68 dBm</li> </ul>	<ul style="list-style-type: none"> <li>1 Mbps: -94 dBm</li> <li>2 Mbps: -91 dBm</li> <li>5.5 Mbps: -89 dBm</li> <li>11 Mbps: -85 dBm</li> </ul>	<ul style="list-style-type: none"> <li>1 Mbps: -94 dBm</li> <li>2 Mbps: -91 dBm</li> <li>5.5 Mbps: -89 dBm</li> <li>6 Mbps: -85 dBm</li> <li>9 Mbps: -84 dBm</li> <li>11 Mbps: -85 dBm</li> <li>12 Mbps: -82 dBm</li> <li>18 Mbps: -80 dBm</li> <li>24 Mbps: -77 dBm</li> <li>36 Mbps: -73 dBm</li> <li>48 Mbps: -69 dBm</li> <li>54 Mbps: -68 dBm</li> </ul>



Table 2 Product Specifications (Continued)

	With 802.11a radio installed	With 802.11b radio installed	With both 802.11a and 802.11b radio installed
<b>Available transmit power settings</b>	<ul style="list-style-type: none"> <li>• 40 mW (16 dBm)</li> <li>• 20 mW (13 dBm)</li> <li>• 10 mW (10 dBm)</li> <li>• 5 mW (7 dBm)</li> </ul> <p>Maximum power setting will vary according to individual country regulations.</p>	<ul style="list-style-type: none"> <li>• 100 mW (20 dBm)</li> <li>• 50 mW (17 dBm)</li> <li>• 30 mW (15 dBm)</li> <li>• 20 mW (13 dBm)</li> <li>• 5 mW (7 dBm)</li> <li>• 1 mW (0 dBm)</li> </ul> <p>Maximum power setting will vary according to individual country regulations.</p>	<p>802.11a:</p> <ul style="list-style-type: none"> <li>• 40 mW (16 dBm)</li> <li>• 20 mW (13 dBm)</li> <li>• 10 mW (10 dBm)</li> <li>• 5 mW (7 dBm)</li> </ul> <p>802.11b:</p> <ul style="list-style-type: none"> <li>• 100 mW (20 dBm)</li> <li>• 50 mW (17 dBm)</li> <li>• 30 mW (15 dBm)</li> <li>• 20 mW (13 dBm)</li> <li>• 5 mW (7 dBm)</li> <li>• 1 mW (0 dBm)</li> </ul> <p>Maximum power setting will vary according to individual country regulations.</p>
<b>Range (typical at maximum transmit power setting, 2.2 dBi gain diversity dipole antenna for 2.4 GHz; 6 dBi gain patch and 5 dBi omni antenna for 5 GHz)</b>	<p>Omni directional Antenna:</p> <ul style="list-style-type: none"> <li>• Indoor: <ul style="list-style-type: none"> <li>– 60 ft (18m) @ 54 Mbps</li> <li>– 130 ft (40m) @ 18 Mbps</li> <li>– 170 ft (52m) @ 6 Mbps</li> </ul> </li> <li>• Outdoor: <ul style="list-style-type: none"> <li>– 100 ft (30m) @ 54 Mbps</li> <li>– 600 ft (183m) @ 18 Mbps</li> <li>– 1000 (304m) ft @ 6 Mbps</li> </ul> </li> </ul> <p>Patch Antenna:</p> <ul style="list-style-type: none"> <li>• Indoor: <ul style="list-style-type: none"> <li>– 70 ft (21m) @ 54 Mbps</li> <li>– 150 ft (45m) @ 18 Mbps</li> <li>– 200 ft (61m) @ 6 Mbps</li> </ul> </li> <li>• Outdoor: <ul style="list-style-type: none"> <li>– 120 ft (36m) @ 54 Mbps</li> <li>– 700 ft (213m) @ 18 Mbps</li> <li>– 1200 ft (355m) @ 6 Mbps</li> </ul> </li> </ul>	<p>Indoor:</p> <ul style="list-style-type: none"> <li>• 130 ft (40m) @ 11 Mbps</li> <li>• 350 ft (107m) @ 1 Mbps</li> </ul> <p>Outdoor:</p> <ul style="list-style-type: none"> <li>• 800 ft (244m) @ 11 Mbps</li> <li>• 2000 ft (610m) @ 1 Mbps</li> </ul>	<p>802.11a Omni directional Antenna:</p> <ul style="list-style-type: none"> <li>• Indoor: <ul style="list-style-type: none"> <li>– 60 ft (18m) @ 54 Mbps</li> <li>– 130 ft (40m) @ 18 Mbps</li> <li>– 170 ft (52m) @ 6 Mbps</li> </ul> </li> <li>• Outdoor: <ul style="list-style-type: none"> <li>– 100 ft (30m) @ 54 Mbps</li> <li>– 600 ft (183m) @ 18 Mbps</li> <li>– 1000 ft (304m) @ 6 Mbps</li> </ul> </li> </ul> <p>802.11a Patch Antenna:</p> <ul style="list-style-type: none"> <li>• Indoor: <ul style="list-style-type: none"> <li>– 70 ft (21m) @ 54 Mbps</li> <li>– 150 ft (45m) @ 18 Mbps</li> <li>– 200 ft (61m) @ 6 Mbps</li> </ul> </li> <li>• Outdoor: <ul style="list-style-type: none"> <li>– 120 ft (36m) @ 54 Mbps</li> <li>– 700 ft (213m) @ 18 Mbps</li> <li>– 1200 ft (355m) @ 6 Mbps</li> </ul> </li> </ul> <p>802.11b Omni directional Antenna:</p> <ul style="list-style-type: none"> <li>• Indoor: <ul style="list-style-type: none"> <li>– 130 ft (40 m) @ 11 Mbps</li> <li>– 350 ft (107 m) @ 1 Mbps</li> </ul> </li> <li>• Outdoor: <ul style="list-style-type: none"> <li>– 800 ft (244 m) @ 11 Mbps</li> <li>– 2000 ft (610 m) @ 1 Mbps</li> </ul> </li> </ul>



Table 2 Product Specifications (Continued)

	With 802.11a radio installed	With 802.11b radio installed	With both 802.11a and 802.11b radio installed
<b>Compliance</b>	<ul style="list-style-type: none"> <li>• Standards:</li> <li><i>Safety:</i></li> <li>– UL 1950</li> <li>– CSA 22.2 No. 950-95</li> <li>– IEC 60950</li> <li>– EN 60950</li> <li><i>Radio Approvals:</i></li> <li>– FCC Part 15.401-15.407</li> <li>– RSS-210 (Canada)</li> <li>– EN 301.893 (Europe)</li> <li>– ARIB STD-T71 (Japan)</li> <li>– AS 4268.2 (Australia)</li> <li><i>EMI and Susceptibility (Class B):</i></li> <li>– FCC Part 15.107 and 15.109</li> <li>– ICES-003 (Canada)</li> <li>– VCCI (Japan)</li> <li>– EN 301.489-1 and -17 (Europe)</li> <li><i>Other:</i></li> <li>– IEEE 802.11a</li> <li>– FCC Bulletin OET-65C</li> <li>– RSS-102</li> </ul>	<ul style="list-style-type: none"> <li>• Standards:</li> <li><i>Safety:</i></li> <li>– UL 1950</li> <li>– CSA 22.2 No. 950-95</li> <li>– IEC 60950</li> <li>– EN 60950</li> <li><i>Radio Approvals:</i></li> <li>– FCC Part 15.247</li> <li>– RSS-139-1, RSS-210 (Canada)</li> <li>– EN 300.328 (Europe)</li> <li>– Telec 33B (Japan)</li> <li>– AS/NZS 3548 (Australia and New Zealand)</li> <li><i>EMI and Susceptibility (Class B):</i></li> <li>– FCC Part 15.107 and 15.109</li> <li>– ICES-003 (Canada)</li> <li>– VCCI (Japan)</li> <li>– EN 301.489-1 and -17 (Europe)</li> <li><i>Other:</i></li> <li>– IEEE 802.11b</li> <li>– FCC Bulletin OET-65C</li> <li>– RSS-102</li> </ul>	<ul style="list-style-type: none"> <li>• Standards:</li> <li><i>Safety:</i></li> <li>– UL 1950</li> <li>– CSA 22.2 No. 950-95</li> <li>– IEC 60950</li> <li>– EN 60950</li> <li><i>Radio Approvals:</i></li> <li>– FCC Part 15.401-15.407</li> <li>– RSS-210 (Canada)</li> <li>– EN 301.893 (Europe)</li> <li>– ARIB STD-T71 (Japan)</li> <li>– AS 4268.2 (Australia)</li> <li>– FCC Part 15.247</li> <li>– RSS-139-1, RSS-210 (Canada)</li> <li>– EN 300.328 (Europe)</li> <li>– Telec 33B (Japan)</li> <li>– AS/NZS 3548 (Australia and New Zealand)</li> <li><i>EMI and Susceptibility (Class B):</i></li> <li>– FCC Part 15.107 and 15.109</li> <li>– ICES-003 (Canada)</li> <li>– VCCI (Japan)</li> <li>– EN 301.489-1 and -17 (Europe)</li> <li><i>Other:</i></li> <li>– IEEE 802.11a</li> <li>– IEEE 802.11b</li> <li>– FCC Bulletin OET-65C</li> <li>– RSS-102</li> </ul>
<b>SNMP compliance</b>	<ul style="list-style-type: none"> <li>• MIB<sup>1</sup> I and MIB II</li> </ul>	<ul style="list-style-type: none"> <li>• MIB I and MIB II</li> </ul>	<ul style="list-style-type: none"> <li>• MIB I and MIB II</li> </ul>
<b>Antenna</b>	<ul style="list-style-type: none"> <li>• Integrated 6 dBi diversity patch (55 degree horizontal, 55 degree vertical beamwidths, 5 dBi diversity omnidirectional with 360 degree horizontal and 40 degree vertical beamwidths)</li> </ul>	<ul style="list-style-type: none"> <li>• Two RP-TNC connectors (antennas optional, none supplied with unit)</li> </ul>	5 GHz: <ul style="list-style-type: none"> <li>• Integrated 6 dBi diversity patch (55 degree horizontal, 55 degree vertical beamwidths, 5 dBi diversity omnidirectional with 360 degree horizontal and 40 degree vertical beamwidths)</li> </ul> 2.4 GHz: <ul style="list-style-type: none"> <li>• Two RP-TNC connectors (antennas optional, none supplied with unit)</li> </ul>



Table 2 Product Specifications (Continued)

	With 802.11a radio installed	With 802.11b radio installed	With both 802.11a and 802.11b radio installed
<b>Security architecture client authentication</b>	<p>Cisco Wireless Security Suite including:</p> <p>Authentication:</p> <ul style="list-style-type: none"> <li>• 802.1X support including LEAP, PEAP, EAP-TLS, EAP-TTLS, and EAP-SIM to yield mutual authentication and dynamic, per-user, per-session WEP keys</li> <li>• MAC address and by standard 802.11 authentication mechanisms</li> </ul> <p>Encryption:</p> <ul style="list-style-type: none"> <li>• Support for static and dynamic IEEE 802.11 WEP keys of 40 bits and 128 bits</li> <li>• Pre-standard TKIP WEP enhancements: key hashing (per-packet keying), message integrity check (MIC) and broadcast key rotation</li> </ul>	<p>Cisco Wireless Security Suite including:</p> <p>Authentication:</p> <ul style="list-style-type: none"> <li>• 802.1X support including LEAP, PEAP, EAP-TLS, EAP-TTLS, and EAP-SIM to yield mutual authentication and dynamic, per-user, per-session WEP keys</li> <li>• MAC address and by standard 802.11 authentication mechanisms</li> </ul> <p>Encryption:</p> <ul style="list-style-type: none"> <li>• Support for static and dynamic IEEE 802.11 WEP keys of 40 bits and 128 bits</li> <li>• Pre-standard TKIP WEP enhancements: key hashing (per-packet keying), message integrity check (MIC) and broadcast key rotation</li> </ul>	<p>Cisco Wireless Security Suite including:</p> <p>Authentication:</p> <ul style="list-style-type: none"> <li>• 802.1X support including LEAP, PEAP, EAP-TLS, EAP-TTLS, and EAP-SIM to yield mutual authentication and dynamic, per-user, per-session WEP keys</li> <li>• MAC address and by standard 802.11 authentication mechanisms</li> </ul> <p>Encryption:</p> <ul style="list-style-type: none"> <li>• Support for static and dynamic IEEE 802.11 WEP keys of 40 bits and 128 bits</li> <li>• Pre-standard TKIP WEP enhancements: key hashing (per-packet keying), message integrity check (MIC) and broadcast key rotation</li> </ul>
<b>Status LEDs</b>	<ul style="list-style-type: none"> <li>• Three indicators on the top panel report association status, operation, error/warning, firmware upgrade, and configuration, network/modem, and radio status.</li> </ul>	<ul style="list-style-type: none"> <li>• Three indicators on the top panel report association status, operation, error/warning, firmware upgrade, and configuration, network/modem, and radio status.</li> </ul>	<ul style="list-style-type: none"> <li>• Three indicators on the top panel report association status, operation, error/warning, firmware upgrade, and configuration, network/modem, and radio status.</li> </ul>
<b>Software Image Network and Inventory support</b>	<ul style="list-style-type: none"> <li>• CiscoWorks RME<sup>2</sup>, CiscoWorks SWIM<sup>3</sup></li> </ul>	<ul style="list-style-type: none"> <li>• CiscoWorks RME, CiscoWorks SWIM</li> </ul>	<ul style="list-style-type: none"> <li>• CiscoWorks RME, CiscoWorks SWIM</li> </ul>
<b>Remote configuration support</b>	<ul style="list-style-type: none"> <li>• BOOTP, DHCP<sup>4</sup>, Telnet, HTTP, FTP,<sup>5</sup> TFTP,<sup>6</sup> and SNMP</li> </ul>	<ul style="list-style-type: none"> <li>• BOOTP, DHCP, Telnet, HTTP, FTP, TFTP, and SNMP</li> </ul>	<ul style="list-style-type: none"> <li>• BOOTP, DHCP, Telnet, HTTP, FTP, TFTP, and SNMP</li> </ul>
<b>Local configuration</b>	<ul style="list-style-type: none"> <li>• Direct console port (RJ-45 interface)</li> </ul>	<ul style="list-style-type: none"> <li>• Direct console port (RJ-45 interface)</li> </ul>	<ul style="list-style-type: none"> <li>• Direct console port (RJ-45 interface)</li> </ul>
<b>Dimensions</b>	<ul style="list-style-type: none"> <li>• 6.562 in. (16.67 cm) wide; 7.232 in. (18.37 cm) deep; 1.660 in. (4.22 cm) high</li> <li>• Mounting bracket adds 0.517 in. (1.31 cm) to the height</li> </ul>	<ul style="list-style-type: none"> <li>• 6.562 in. (16.67 cm) wide; 7.232 in. (18.37 cm) deep; 1.660 in. (4.22 cm) high</li> <li>• Mounting bracket adds 0.517 in. (1.31 cm) to the height</li> </ul>	<ul style="list-style-type: none"> <li>• 6.562 in. (16.67 cm) wide; 7.232 in. (18.37 cm) deep; 1.660 in. (4.22 cm) high</li> <li>• Mounting bracket adds 0.517 in. (1.31 cm) to the height</li> </ul>
<b>Weight</b>	<ul style="list-style-type: none"> <li>• 26 oz (737g) add 6.4 oz (181g) for mounting bracket</li> </ul>	<ul style="list-style-type: none"> <li>• 25.6 oz (724g) add 6.4 oz (181g) for mounting bracket</li> </ul>	<ul style="list-style-type: none"> <li>• 27.6 oz (783g) add 6.4 oz (181g) for mounting bracket</li> </ul>



Table 2 Product Specifications (Continued)

	With 802.11a radio installed	With 802.11b radio installed	With both 802.11a and 802.11b radio installed
<b>Environmental</b>	• -4° to 122°F (-20° to 50°C), 10 to 90% humidity (noncondensing)	• -4° to 131°F (-20° to 55°C), 10 to 90% humidity (noncondensing)	• -4° to 122°F (-20° to 50°C), 10 to 90% humidity (noncondensing)
<b>Processor</b>	• IBM PowerPC405 200 MHz	• IBM PowerPC405 200 MHz	• IBM PowerPC405 200 MHz
<b>System Memory</b>	• 16 Mbytes RAM • 8 Mbytes FLASH	• 16 Mbytes RAM • 8 Mbytes FLASH	• 16 Mbytes RAM • 8 Mbytes FLASH
<b>Input power requirements</b>	• 90 to 240 VAC +/- 10% (power supply) • 48 VDC +/- 10%(device)	• 90 to 240 VAC +/- 10% (power supply) • 48 VDC +/- 10%(device)	• 90 to 240 VAC +/- 10% (power supply) • 48 VDC +/- 10%(device)
<b>Power Draw</b>	• 8 watts, RMS	• 6 watts, RMS	• 11 watts, RMS
<b>Warranty</b>	• One year	• One year	• One year

1. Management Information Base
2. CiscoWorks Resource Manager Essentials
3. Software Image Manager
4. Dynamic Host Configuration Protocol
5. File Transfer Protocol
6. Trivial File Transfer Protocol

Table 3 Product System Requirements

Feature	System requirement
<b>Standard 802.1X-compliant user-level authentication and dynamic encryption keying</b>	One of the following RADIUS servers: <ul style="list-style-type: none"> <li>• Cisco Secure Access Control Server Version 3.0 or greater</li> <li>• Cisco Access Registrar Version 1.7 or greater</li> <li>• Funk Software Steel Belted RADIUS Server Version 3.0 or greater</li> <li>• Interlink Networks RAD-Series RADIUS Server Version 5.1 or greater</li> </ul>
<b>CiscoWorks RME/SWIM</b>	• CiscoWorks LMS <sup>1</sup> or RWAN <sup>2</sup>
<b>Line power over Ethernet support (2.4 GHz radio only)</b>	<ul style="list-style-type: none"> <li>• Cisco AIR-PSINJSYS1200= single-port power injector</li> <li>• Cisco Catalyst® 3524-PWR XL Switch</li> <li>• Cisco Catalyst 4006 and 6500 Series switches with inline power</li> <li>• Cisco WS-PWR-PANEL Midspan Power Patch Panel</li> </ul>
<b>Line power over Ethernet support (both 5 GHz and 2.4 GHz radio)</b>	• Cisco AIR-PSINJSYS1200= single-port power injector
<b>Line power over Ethernet support (5 GHz radio only)</b>	• Cisco AIR-PSINJSYS1200= single-port power injector

1. LAN Management Solution
2. Routed WAN Management Solution

## Cisco SMARTnet Support and SMARTnet Onsite Support

Operational technical support service for maximizing network availability is offered through Cisco SMARTnet™ support and SMARTnet Onsite support. Cisco SMARTnet support augments the resources of your operations staff; it provides them access to a wealth of expertise, both online and via telephone; the ability to refresh their system software at will; and a range of hardware advance-replacement options. Cisco SMARTnet Onsite support provides all SMARTnet services and complements the hardware advance-replacement feature by adding the services of a field engineer, which can be critical for those locations where staffing is insufficient or unavailable to perform parts replacement activities.

To learn more about service and support for the Cisco Aironet 1200 Series, visit <http://www.cisco.com/warp/public/cc/serv/mkt/sup/tsssv/opmsup/smtom/index.shtml>



Corporate Headquarters  
Cisco Systems, Inc.  
170 West Tasman Drive  
San Jose, CA 95134-1706  
USA  
[www.cisco.com](http://www.cisco.com)  
Tel: 408 526-4000  
800 553-NETS (6387)  
Fax: 408 526-4100

European Headquarters  
Cisco Systems International BV  
Haarlerbergpark  
Haarlerbergweg 13-19  
1101 CH Amsterdam  
The Netherlands  
[www-europe.cisco.com](http://www-europe.cisco.com)  
Tel: 31 0 20 357 1000  
Fax: 31 0 20 357 1100

Americas Headquarters  
Cisco Systems, Inc.  
170 West Tasman Drive  
San Jose, CA 95134-1706  
USA  
[www.cisco.com](http://www.cisco.com)  
Tel: 408 526-7660  
Fax: 408 527-0883

Asia Pacific Headquarters  
Cisco Systems, Inc.  
Capital Tower  
168 Robinson Road  
#22-01 to #29-01  
Singapore 068912  
[www.cisco.com](http://www.cisco.com)  
Tel: +65 317 7777  
Fax: +65 317 7799

Cisco Systems has more than 200 offices in the following countries and regions. Addresses, phone numbers, and fax numbers are listed on the [Cisco Web site at www.cisco.com/go/offices](http://www.cisco.com/go/offices)

Argentina • Australia • Austria • Belgium • Brazil • Bulgaria • Canada • Chile • China PRC • Colombia • Costa Rica • Croatia  
Czech Republic • Denmark • Dubai, UAE • Finland • France • Germany • Greece • Hong Kong SAR • Hungary • India • Indonesia • Ireland  
Israel • Italy • Japan • Korea • Luxembourg • Malaysia • Mexico • The Netherlands • New Zealand • Norway • Peru • Philippines • Poland  
Portugal • Puerto Rico • Romania • Russia • Saudi Arabia • Scotland • Singapore • Slovakia • Slovenia • South Africa • Spain • Sweden  
Switzerland • Taiwan • Thailand • Turkey • Ukraine • United Kingdom • United States • Venezuela • Vietnam • Zimbabwe

All contents are Copyright © 1992-2002, Cisco Systems, Inc. All rights reserved. SMARTnet is a trademark, and Aironet, Cisco, Cisco IOS, Cisco Systems, and the Cisco Systems logo are registered trademarks of Cisco Systems, Inc. and/or its affiliates in the U.S. and certain other countries.

All other trademarks mentioned in this document or Web site are the property of their respective owners. The use of the word partner does not imply a partnership relationship between Cisco and any other company. (0206R)